

## Singel<sup>TM</sup> 5100

With our new **Singel<sup>TM</sup> 5100** lift you get one of the smallest lifts in the world. The lift has many similarities with its big brother, **Roomer<sup>TM</sup> 5200**. The main difference is that the **Singel<sup>TM</sup> 5100** has only one belt instead of two and cannot be used for horizontal patient transfer from room to room. The price of the **Singel<sup>TM</sup> 5100** is also lower than the price of **Roomer<sup>TM</sup> 5200**.

The great benefit with the lift is the ability to use it in several rooms or apartments because of its 100% mobility. The lift can be placed on a cart for quick and easy transfer to different rooms. This means you have great cost effectiveness compared to other lifting systems.

**Singel<sup>TM</sup> 5100** has new user-friendly features compared to the previous version.

- **Telescopic Bar<sup>TM</sup>** - three different width in one bar.
- Increased lift capacity - 220kg/480lbs.
- Stronger motor with two speeds and soft start and soft stop.
- Built-in memory.
- Charging batteries through the remote control.
- Improved safety functions.

The new **Telescopic Bar<sup>TM</sup>** combined with the possibility of 2-, 3- and 4-point suspension enables the users to create the most flexible lifting solution.

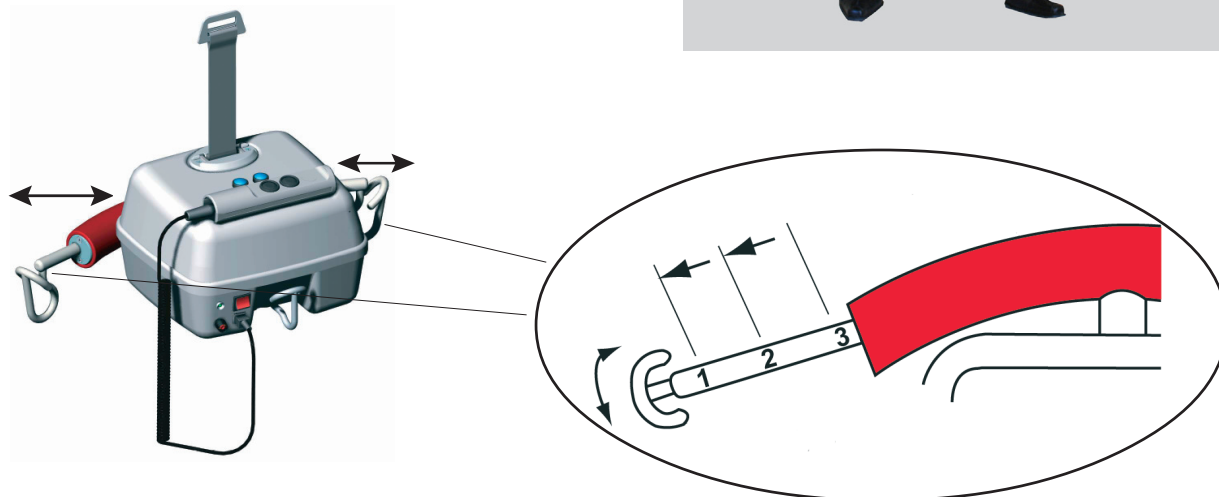

## Product description

1. Overhead lift Singel™5100
2. Charger
3. Remote control
4. UP-button (Remote control)
5. DOWN-button (Remote control)
6. Belt
7. Clamp
8. Telescopicbar™
9. Hanger bar hook
10. UP-button (On lift)
11. DOWN-button (On lift)
12. Leg hook
13. Main switch/Emergency stop
14. Indicator lamp
15. Emergency lowering button
16. Connection remote control
17. Cable

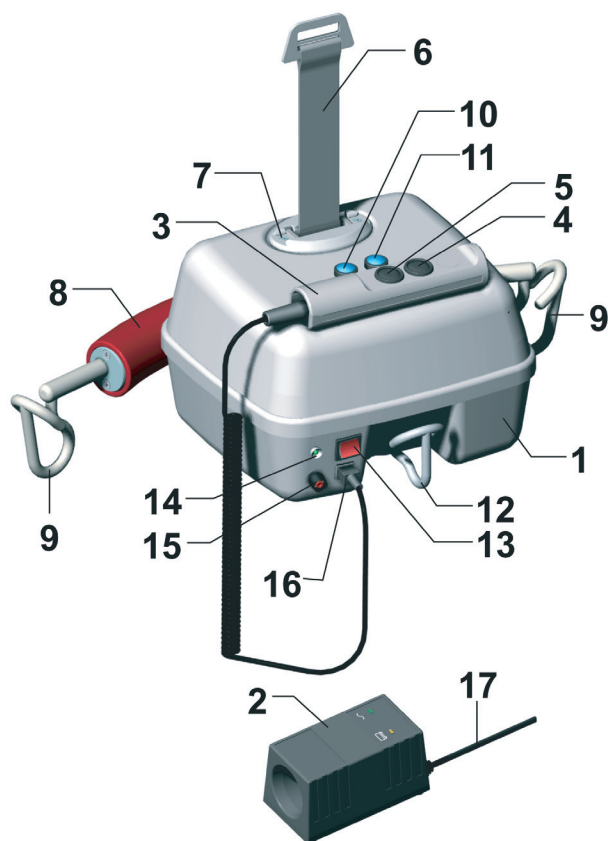

## Technical specification

Max lift weight.....220kg/480lbs  
 Dimensions.....450 x 325 x 175 mm  
 Product weight.....9,9 kg/21.8 lbs  
 Battery.....2 x 12V 3.2 Ah  
 Type and class.....B class III IPX 1  
 Battery charger.....Input 100-250V, AC 50-60Hz  
 .....Output 24V, 0.5A DC  
 Lifting speed.....Level 1: 1.8 m/min  
 .....Level 2: 3.0 m/min  
 .....(Only when unloaded)

Emergency lowering.....Electronic  
 Start/Stop.....Softstart/Softtop  
 Indicator lamp:  
 Stand by.....Flashing green  
 Active.....Consistent green  
 Low voltage.....Flashing red  
 Error.....Consistent red  
 Telescopicbar™ -adjustable in three different widths, 35, 45 and 55cm  
 Remote control.....Class IP 65  
 Charging through the remote control.

***Distributed by:***

Flagship Mobility Inc.  
 513 S. Clewell Street  
 Bethlehem, PA. 18015  
 Tel: 1 866 694-6862  
 Fax: 610 694-8905  
 email: sales@flagshipmobility.com